

DISPOSIZIONE IMPIANTI/ DISPOSITION SYSTEMS

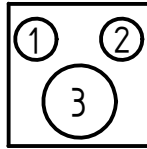

- 1- Calda/Warm 3/8"
- 2- Fredda/Cold 3/8"
- 3- Scarico/Drain diametro 40 mm

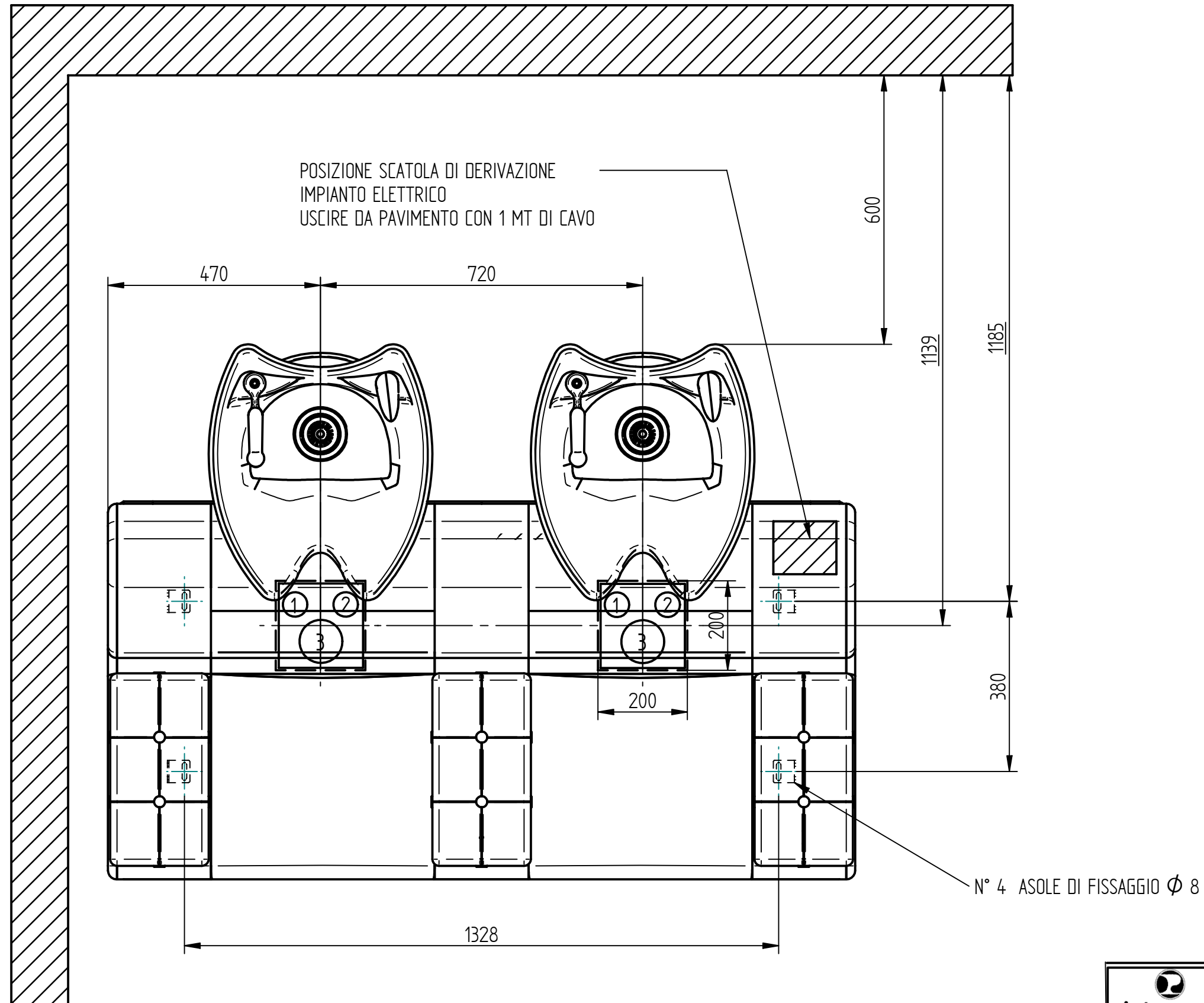

<p>PIETRANERA SPA Via Masaccio n°2 RE Tel. 0522/516510 Fax 0522/514669</p>	DATA:	SCALA:	AUTORE:
			F.I.
	GRUPPO:		CODICE:
			526
	DENOMINAZIONE:		DISEGNO N°
	LAVAGGIO PACHA' 2 POSTI		